

## BIPM GPS calibration information sheet

Laboratory:	NMI Sydney, Australia	
Date and hour of the beginning of measurements:	27/11/2003, MJD 52970	
Date and hour of the end of measurements:	25/01/2004, MJD 53029	
<b>Receiver setup information</b>		
	<b>Local:</b>	<b>Portable: NML</b>
• Maker:	NMI/Topcon	NMI/Topcon
• Type:	Topcon Euro-80	Euro-80 Dual Frequency
• Serial number:	8RQRKXT534	8R633IOLON4
• Receiver internal delay (GPS) :	46.5 ns (uncalibrated)	44.79 ns (uncalibrated)
• Receiver internal delay (GLO) :		
• Antenna cable identification:	TCDF-1	NML IF
Corresponding cable delay :	(75.9 ± 1.0) ns	(159.8 ± 1.0) ns
• UTC cable identification:	UTC(AUS) 9.1.02	APMP Portable
Corresponding cable delay :	(76.0 ± 1.0) ns	(85.9 ± 1.0) ns
Delay to local UTC :	(76.0 ± 1.0) ns	(85.9 ± 1.0) ns
• Receiver trigger level:	0.5V	0.5 V
• Coordinates reference frame:	ITRF93	ITRF2000 @ 18/12/2003
Latitude or X m	-4648200.298	-4648204.271
Longitude or Y m	2560484.03	2560477.026
Height or Z m	-3526505.358	-3526504.952
<b>Antenna information</b>		
	<b>Local:</b>	<b>Portable:</b>
• Maker:	Topcon	Topcon/Javad
• Type:	Regant-1	MarAnt
• Serial number:	RA0122	MAGGD #0191
If the antenna is temperature stabilised		
• Set temperature value :		—
<b>Antenna cable information</b>		
• Maker:		Rojone
• Type:		LMR400
• Is it a phase stabilised cable:		No
• Length of cable outside the building :		10m
<b>General information</b>		
• Rise time of the local UTC pulse:		≤ 4ns
• Is the laboratory air conditioned:		Yes
• Set temperature value and uncertainty :		(20 ± 2) °C
• Set humidity value and uncertainty :		(50 ± 10) %
<b>Cable delay control</b>		
Cable identification	delay measured by NML	delay measured by local method
NML-IF Antenna cable	(159.8 ± 1.0) ns	

## Plot of the experiment set-up:

Link to the local UTC of both receivers and Antenna positions

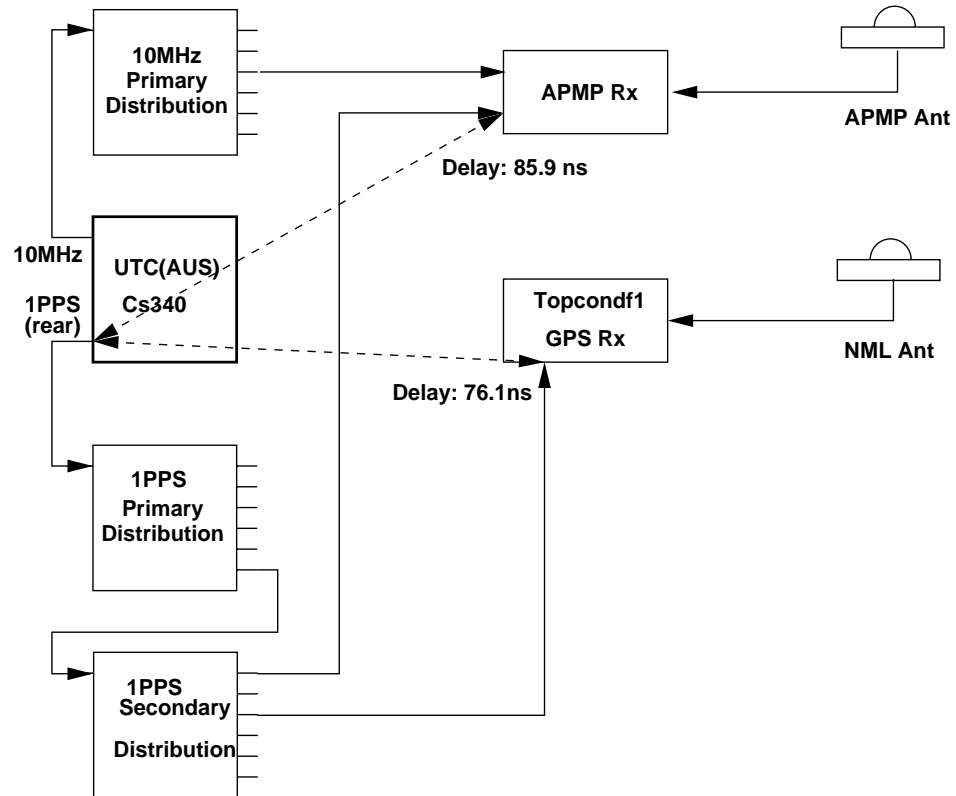

## Description of the local method of cable delay measurement:

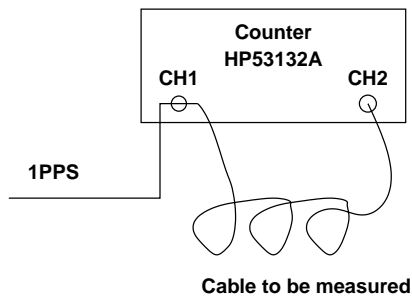

	CH1	CH2
Trigger	1.0V	1.0V
Termination	1M	50 ohm

Mode: Time interval Ch1 to Ch2

Notes:

1. For antenna measurements, a TNC to BNC adapter was used on each end of the cable.
2. Delay Values are Mean and Standard Deviation of 100 measurements.

We observe a typical day-to-day variation of  $\pm 0.5$  ns in the delay measured for a given cable, and we therefore estimate the uncertainty of this method at  $\pm 1$  ns.

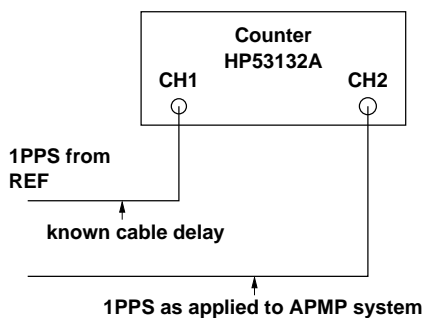

	CH1	CH2
Trigger	1.0V	1.0V
Termination	50 ohm	50 ohm

Mode: Time interval Ch1 to Ch2

1PPS delay to APMP system is "known cable delay" plus measurement.